

# COMPONENTES Y SÍMBOLOS ELÉCTRICOS

Completa la siguiente tabla seleccionando el nombre del componente correspondiente a cada imagen y arrastrando el símbolo eléctrico que le corresponda:

FAMILIA	NOMBRE	IMAGEN	SÍMBOLO
			
			
			
			
			
			
			
			
			
			
			

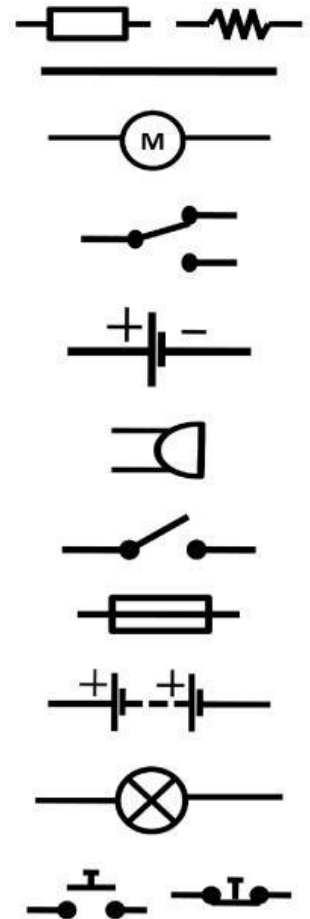

Indica el nombre del elemento señalado y la familia a la que pertenece:

**ELEMENTO DE PROTECCIÓN**

**CONDUCTOR**

**ELEMENTO DE CONTROL**

**RECEPTOR**

**GENERADOR**

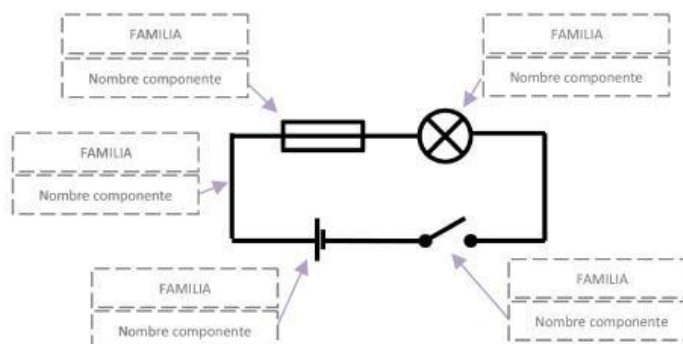

Pila

Bombilla

Interruptor

Fusible

Cable