

PREP II

REVISION FOR THE FINAL TEST

UNIT 1

1. Look and choose the correct option



jump / run



rollerblade / dance



climb / jump



ride a bike / dance



jump / rollerblade

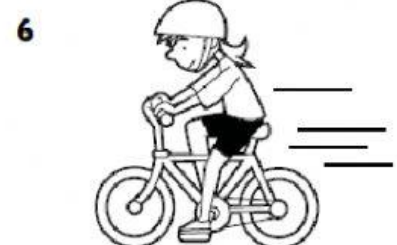

run / ride a bike

2. Look and write

ride a bike ~~dance~~ jump rollerblade run climb



1 I can dance.

4 I can _____.

2 I can't _____.

5 I can _____.

3 I can't _____.

6 I can't _____.

3. Put in the correct place.

~~cold~~ hot thirsty cold ~~hungry~~ hot
happy hot sad angry cold tired



I'm cold.

I'm hungry.



I'm _____.

I'm _____.



I'm _____.

I'm _____.



I'm _____.

I'm _____.



I'm _____.

I'm _____.



I'm _____.

I'm _____.

UNIT 2

1. Match



bus

lorry

train

motorbike

plane

taxi



2. Write.

big fast ~~long~~ old new short slow small

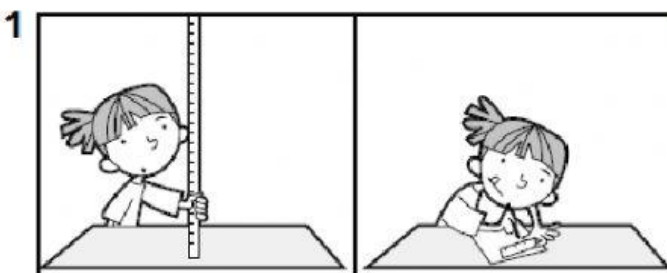

long

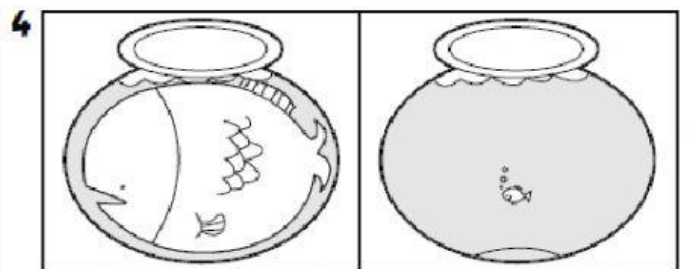
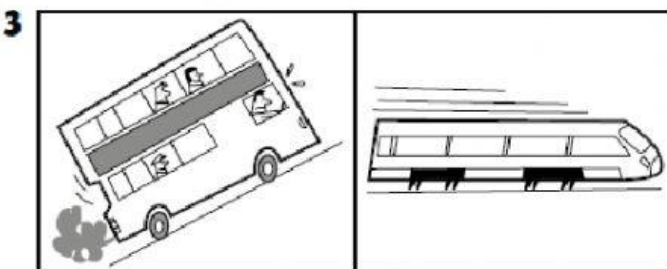
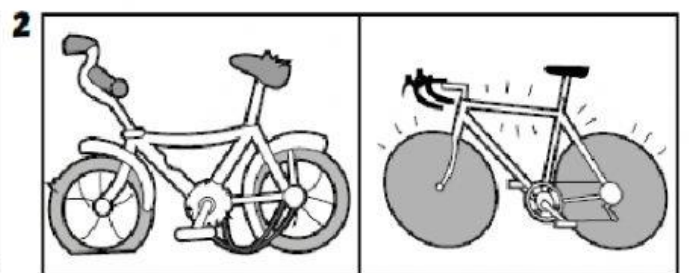

3. Look and write.

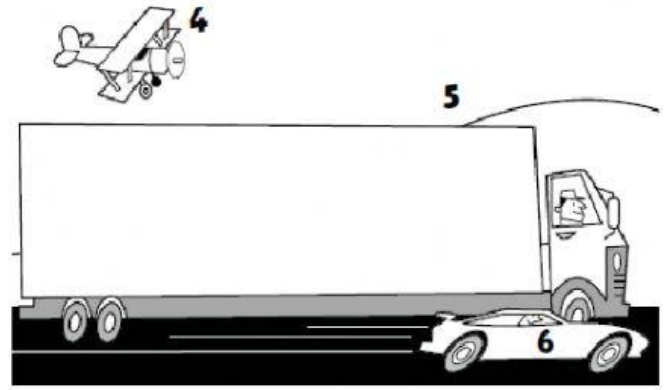
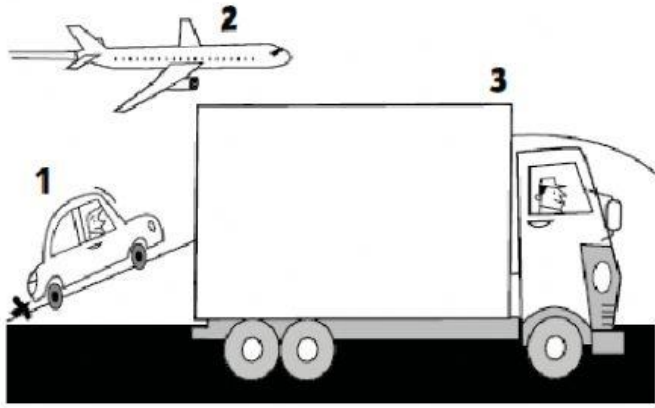

plane slow big

long fast old

1 It's a slow car.

2 It's a new _____.

3 It's a _____ lorry.

4 It's an _____.

5 It's a _____.

6 It's a _____.

UNIT 3

1. Follow and write.

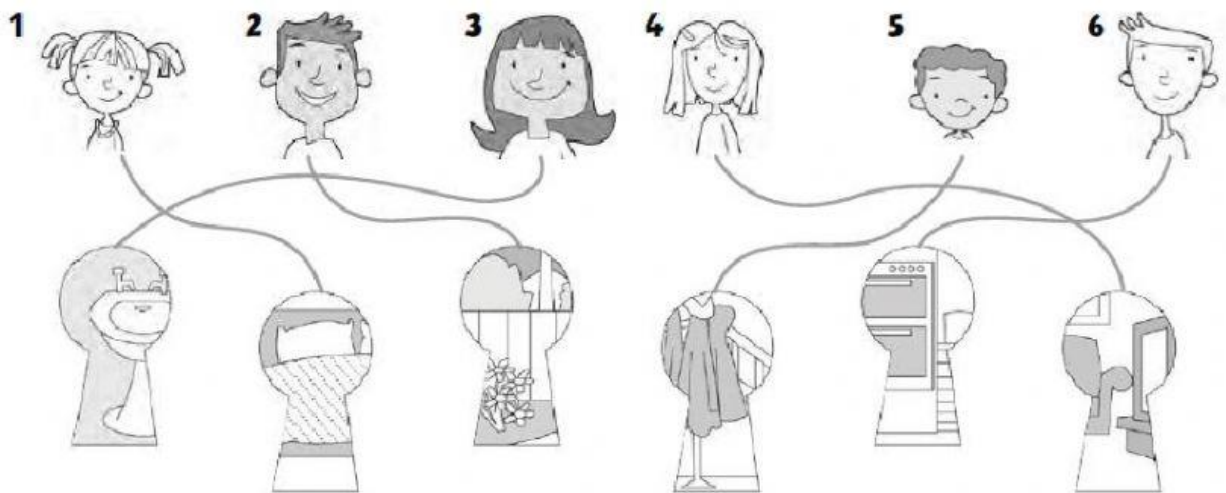

1 She's in the bedroom.

2 He's in the _____.

3 She's in the _____.

4 She's in the _____.

5 He's in the _____.

6 He's in the _____.

2. Look and write

bed bird box cupboard flowers table tree scooter

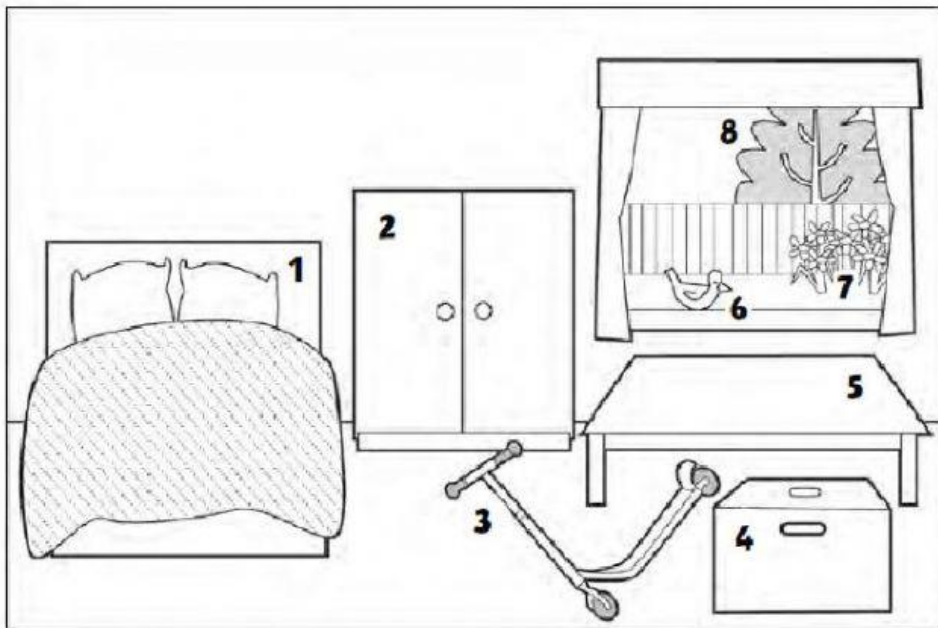

- 1 bed
- 2 _____
- 3 _____
- 4 _____
- 5 _____
- 6 _____
- 7 _____
- 8 _____

3. Look at the pictures. First, choose the correct option, then write.

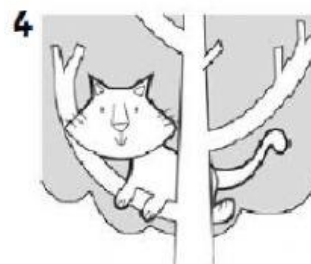
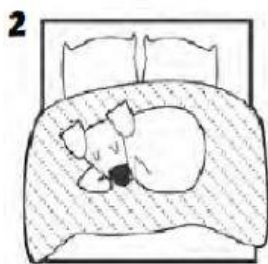

1 The car is **in / on** the box.

2 The dog is **in / on** the _____.

3 The girl is **in / on** the _____.

4 The cat is **in / on** the _____.

5 The _____ is **in / on** the _____.

6 The _____ is **in / on** the _____.

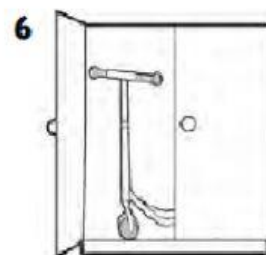
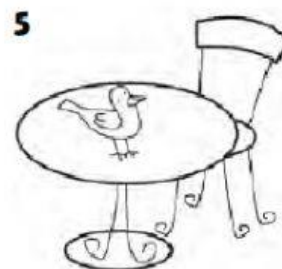

UNIT 4

1. Put the words in the correct blank.

snake fox bat mouse frog hedgehog

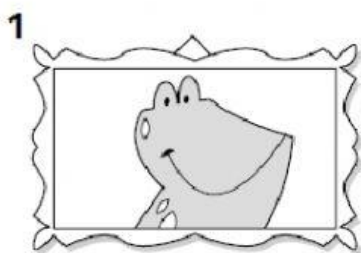

frog

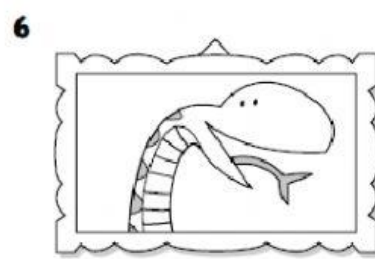
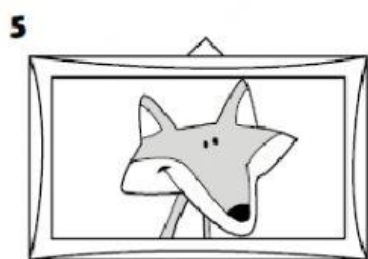
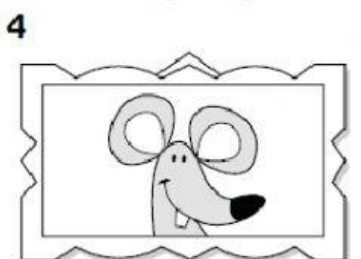
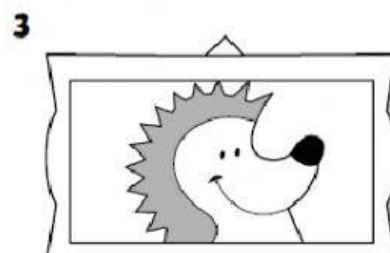
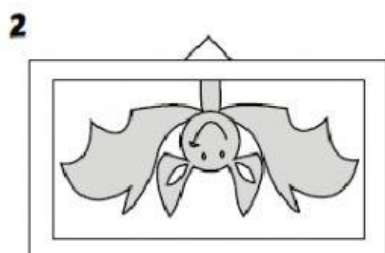

2. Look and write. Read and select the correct option.

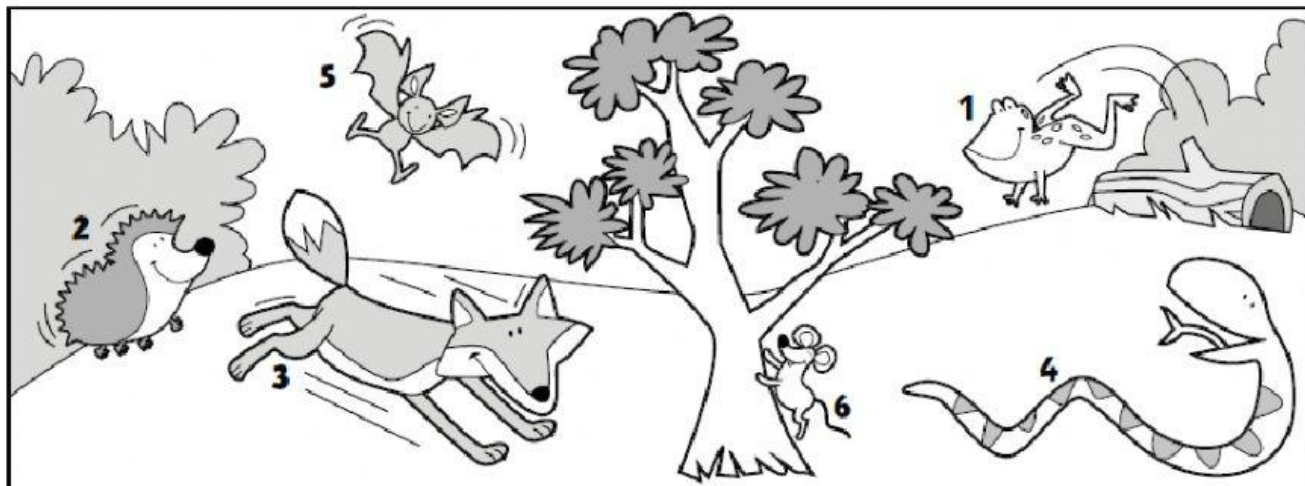

1 It / jump.

4 It / jump.

2 It / fly.

5 It / run.

3 It / run.

6 It / climb.