

## Chapter Test on Measurements, Weight, Density & Force

Name:

Date :

1. Write the SI units for each of the physical quantities. Write the word (unit) not the symbol.

|   |              |  |
|---|--------------|--|
| A | Speed        |  |
| B | acceleration |  |
| C | momentum     |  |
| D | velocity     |  |
| E | displacement |  |
| F | density      |  |
| G | volume       |  |
| H | mass         |  |
| I | weight       |  |
| J | energy       |  |

2. For the following non-SI units, write the symbol of its SI units.

|   |                              |  |
|---|------------------------------|--|
| A | Gram per cubic centimeters   |  |
| B | Newton per cubic centimeters |  |
| C | Gram-meter per minute        |  |
| D | Kilometer per minute         |  |
| E | milligram                    |  |

3. Match the formula with the corresponding quantities it measures.

|  |                 |
|--|-----------------|
|  | density         |
|  | volume          |
|  | weight          |
|  | mass            |
|  | displaced water |

|   |                                      |
|---|--------------------------------------|
| A | <i>final volume – initial volume</i> |
| B | <i>mass x gravitational constant</i> |
| C | <i>density x mass</i>                |
| D | <i>mass ÷ volume</i>                 |
| E | <i>density x volume</i>              |
| F | <i>length x width x height</i>       |

4. The stone of mass 90 grams is weighed on a spring scale measured in Newtons. Show the necessary working.

a. Convert 90 grams to kilograms.

b. What will be the weight reading of the stone on the spring scale?

c. The stone is taken to the moon where the gravitational constant is 1.6N/kg. Calculate the weight of the stone on the surface of the moon.

d. The stone is taken to Mars where the gravitational constant is 3.4N/kg. Calculate the weight of the stone on the surface of Mars.

5. A student checks the purity of a small, uniform bar of gold by measuring its density. He measures the dimensions of the bar. The values are shown below.

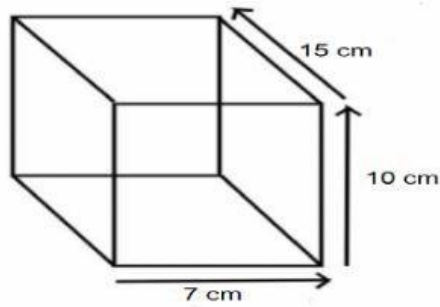

- a. Calculate the volume of the bar of gold.
  
  
  
  
  
  
  
  
  
  
- b. Calculate the density of gold if the mass is 19,950 grams.

6. A simplified illustration of the main forces  $F$ , acting on a swimmer and the wall as she pushes off the wall of a swimming pool. After pushing off the wall, she rises to the surface of the water and swims on the surface.

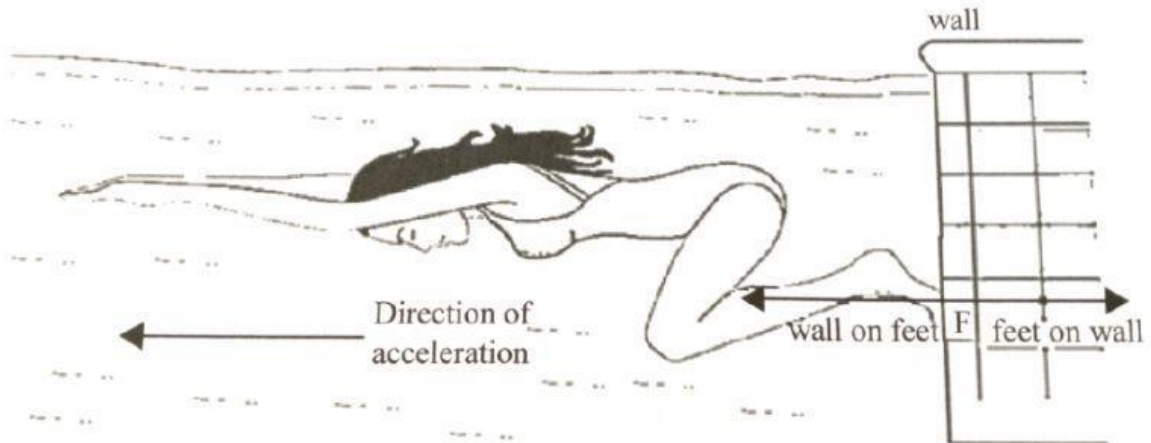

- a. Which law of motion is demonstrated by this swimmer as she pushes against the wall?

- b. Explain how the law named in an (i) is demonstrated as she swims on the water's surface.
- c. The swimmer whose mass is 60kg pushes off the wall of the pool with a force of 22N.
- (i) How much force is exerted on the swimmer by the wall?
- (ii) What is the swimmer's acceleration as she leaves the wall?

## MULTIPLE CHOICE QUESTIONS

1. The diagram shows reading on an ammeter.

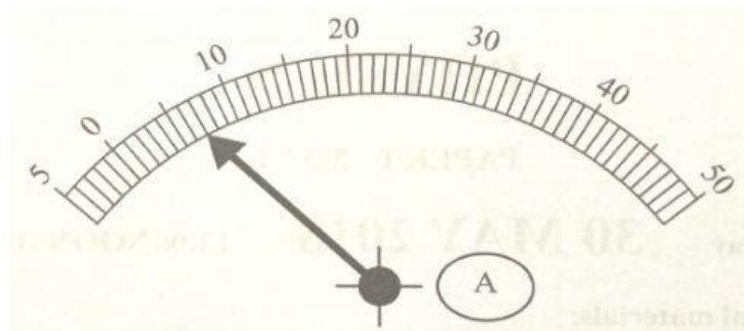

What is the reading on the ammeter?

- A. 0.7A  
B. 1.2 A  
C. 7.0 A  
D. 12.0 A
2. Which pair of quantities have the same units?
- A. acceleration and speed  
B. power and work  
C. weight and drag  
D. moment and momentum

3. A rock is taken from the Earth to the Moon. Which row shows what happens to the mass and weight of the rock on the moon compared to Earth?

|   | mass           | weight    |
|---|----------------|-----------|
| A | decrease       | decrease  |
| B | increase       | increase  |
| C | Stays the same | decrease  |
| D | Stays the same | increases |

4. The diagram shows the forces acting on four objects A, B, C, and D. Which diagram shows the object that only has a net force of 1N acting downwards?

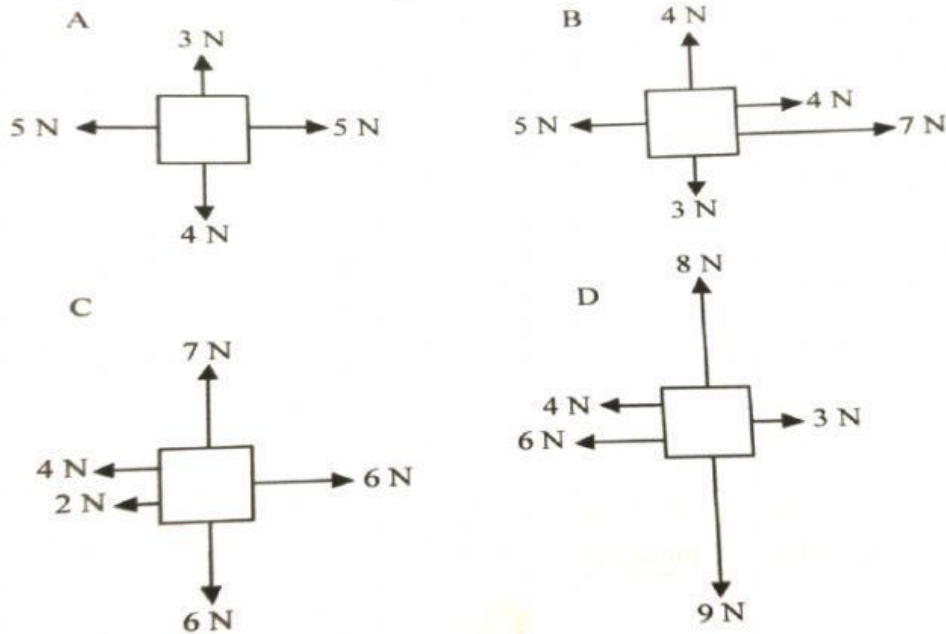

5. The diagram shows a submarine moving in the direction shown by the arrow.

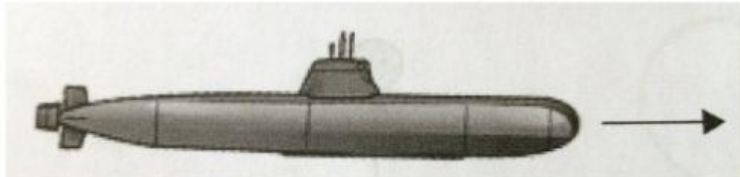

What term is used for the force acting against the motion of the submarine?

- A. Drag      B. Thrust      C. Upthrust      D. Weight

6. Two identical stones with a total mass of 80 grams were placed in 30 cm<sup>3</sup> of water in a measuring cylinder. The water level increases to 40cm<sup>3</sup>.

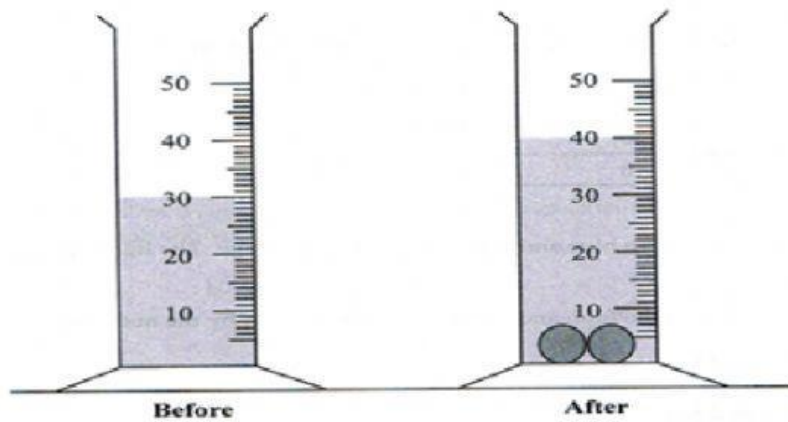

What is the density of the stones?

- A. 2.5 g/cm<sup>3</sup>
- B. 8.0 g/cm<sup>3</sup>
- C. 5.0 g/cm<sup>3</sup>
- D. 10 g/cm<sup>3</sup>

7. A student wishes to measure the volume of a liquid, using a measuring cylinder. Which diagram shows how this can be done most accurately?

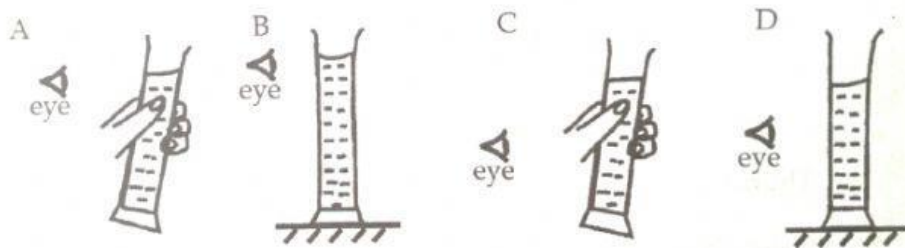

8. A simple balance has two pans suspended from the ends of arms of equal length. When it is balanced, the pointer is at 0.

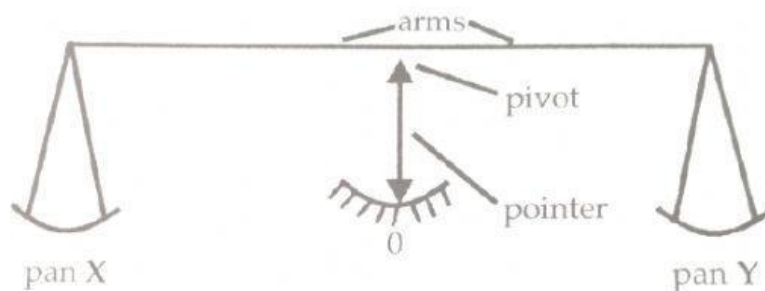

A total of four masses is placed on the pans, with one or more on pan X, and the rest on pan Y. Which combination of masses can be used to balance the pans?

- A. 1g, 1g, 5g, 10g
- B. 1g, 2g, 2g, 5g
- C. 2g, 5g, 5g, 10g
- D. 2g, 5g, 10g, 10g

9. The diagram below shows a book resting on a slope. In which direction does the weight of the book act?

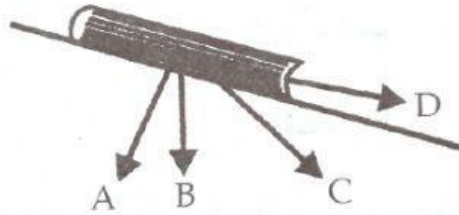

10. A student finds the mass and volume of three solids as shown in the table.

| object | mass(g) | Volume (cm <sup>3</sup> ) |
|--------|---------|---------------------------|
| 1      | 0.5     | 0.1                       |
| 2      | 10      | 20                        |
| 3      | 50      | 75                        |

Which objects will float in pure water?

- A. 1 only
- B. 1 and 2
- C. 2 only
- D. 2 and 3

11. An astronaut's boots weigh 100N on earth where the force of gravity is 10N/kg. How much will they weigh on Mars, where the force of gravity is 4N/kg?

- A. 25N
- B. 40N
- C. 250N
- D. 400N

12. Calculate the mass of the air in the room shown, if air has a density of 1.3kg/m<sup>3</sup>.

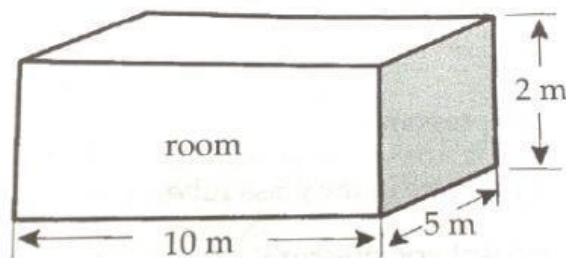

- A. 13kg
- B. 26 kg
- C. 65 kg
- D. 130 kg

13. Which object has a resultant force of 5N to the right?

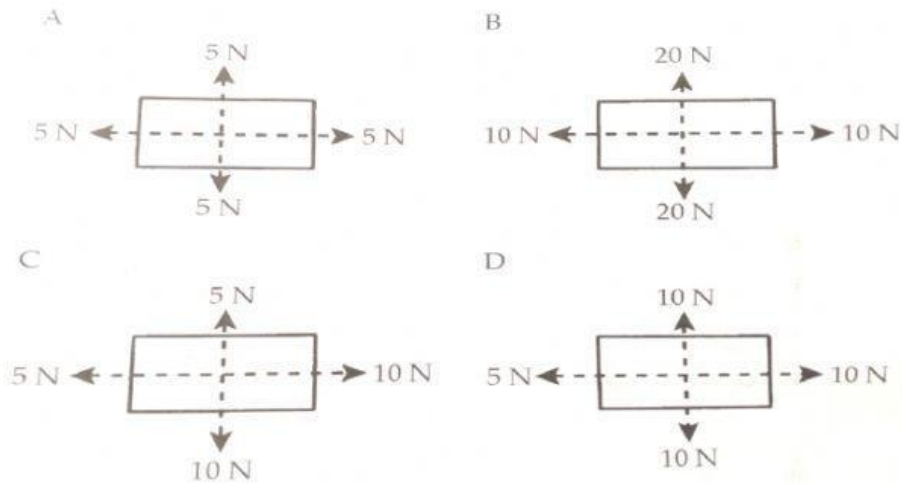

14. The masses of a measuring cylinder before and after pouring some liquid are shown in the diagram.

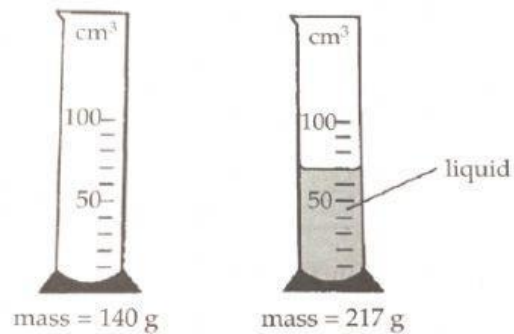



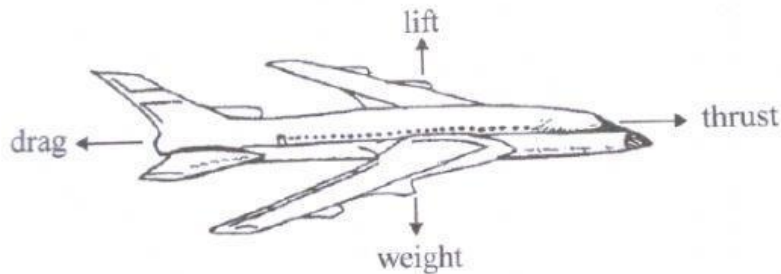

What is the density of the liquid?

- A.  $\frac{217}{52} \text{ g/cm}^3$     B.  $\frac{217}{70} \text{ g/cm}^3$     C.  $\frac{77}{52} \text{ g/cm}^3$     D.  $\frac{77}{70} \text{ g/cm}^3$

15. Whilst flying horizontally at a constant speed, the pilot increases the lift and drag of the aircraft, by the same amount.



In which direction could the resultant force act on the aircraft?

| A   | B   | C   | D   |
|---|---|---|---|
|  |  |  |  |

16. The diagram shows a 150g wooden block and its dimensions.

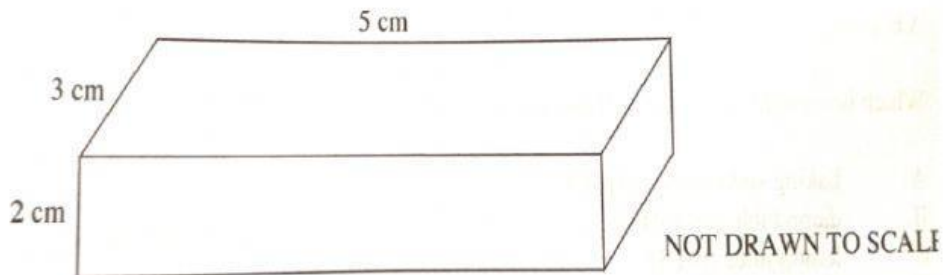

What is the density of the block?

- A.  $2\text{g/cm}^3$       B.  $3\text{g/cm}^3$       C.  $4\text{g/cm}^3$       D.  $5\text{g/cm}^3$

17. Two soccer players simultaneously kick a soccer ball with forces of 75N and 125N in opposite directions as shown in the diagram.

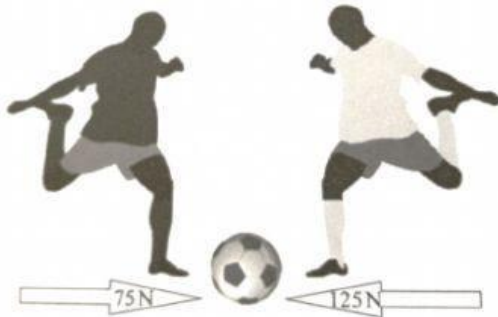

What is the net force of the ball and in what direction it will move?

- A. 75N to the right  
B. 125N to the left  
C. 50 N to the right  
D. 50 N to the left