

**POLYGON: AREA: RECTANGLE, SQUARE, PARALLELOGRAM & TRAPEZOID**

Name: \_\_\_\_\_ Number: \_\_\_\_\_ Grade: \_\_\_\_\_

Check your answers, take pictures and upload image via Class Point/Line

**RECTANGLE & TRIANGLE**

**Question 1:** Calculate the area of each of these rectangles

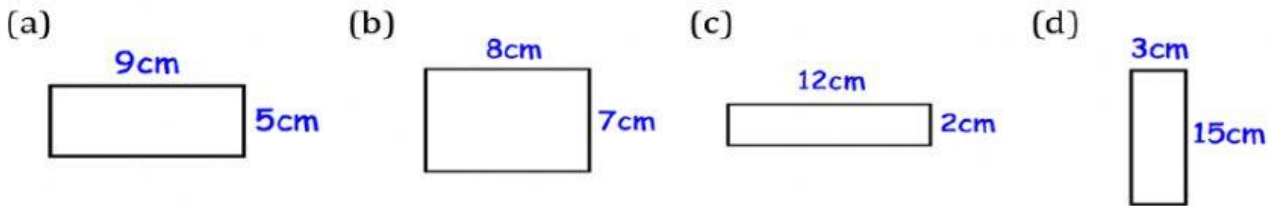

Answer: (a) \_\_\_\_\_ (b) \_\_\_\_\_ (c) \_\_\_\_\_ (d) \_\_\_\_\_

**Question 2:** Work out the area of each of these squares

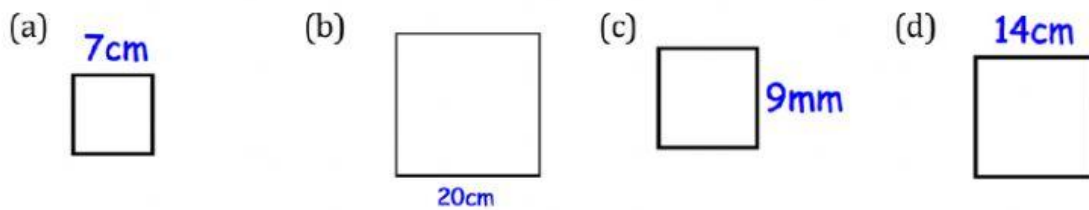

drag the answers for question 1 & 2 from the table below;

45	81	400	49
24	196	56	45

**Question 3:** Work out the area of each of these rectangles (answers in 'm<sup>2</sup>')

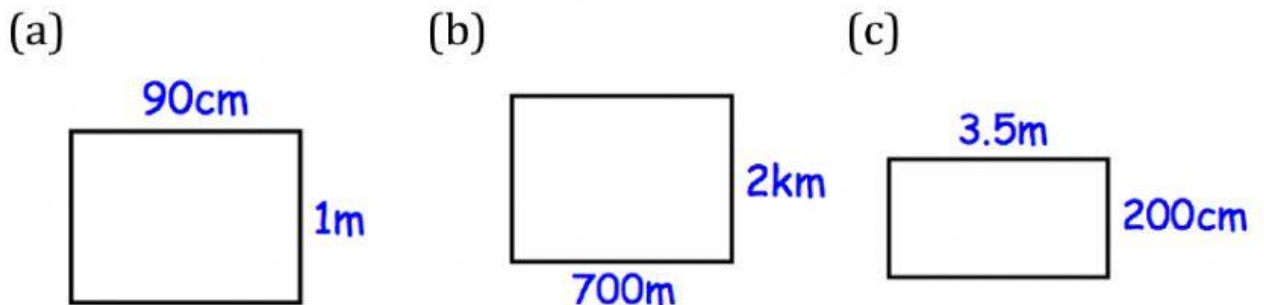

Answer: (a) \_\_\_\_\_ (b) \_\_\_\_\_ (c) \_\_\_\_\_

**Question 4:** The area of each of these rectangles have been given. Find the length of the missing sides.

(a)

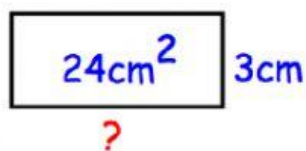

(b)

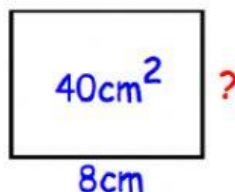

(c)



drag the answers for question 3 & 4 from the table below;

5	7	8	1400000	2	0.9
---	---	---	---------	---	-----

**Apply 1:** A farmer has a field that is 300m long and 70m wide. Calculate the area of the field.



AREA: \_\_\_\_

**Apply 2:** These two rectangles have the same area. Find the length of the second rectangle.

X = \_\_\_\_



**Apply 3:** A rectangle has an area of  $80\text{cm}^2$  and a perimeter of 48cm. Find the length and width of the rectangle

Length: \_\_\_\_ Width: \_\_\_\_

**Apply 4:** A football pitch is 110m long and has a perimeter of 360m. Find the area of the football pitch.



Area: \_\_\_\_

Drag the answers from the table below to the apply: 1,2,3,4

7700	200	4	21000	20
------	-----	---	-------	----

## Parallelogram;

**Question 1:** The following parallelograms are drawn on centimeters-squared paper. Find the area of each. **Answer:** (a) \_\_\_\_\_ (b) \_\_\_\_\_

(a)

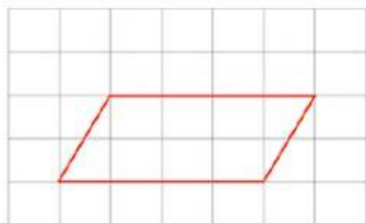

(b)

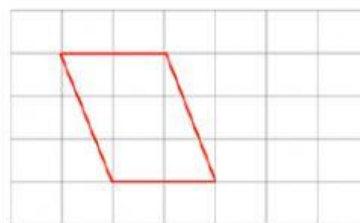

**Question 2:** Work out the area of each of the parallelograms below.

(a)

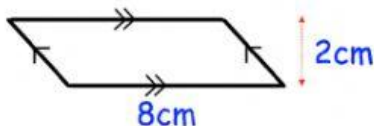

(a) \_\_\_\_\_

(b)

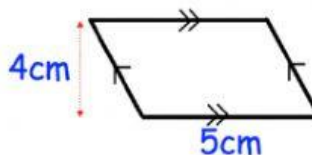

(b) \_\_\_\_\_

(c)

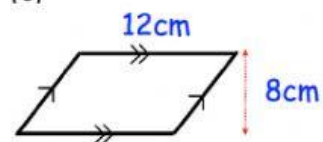

(c) \_\_\_\_\_

**Question 4:** The areas of each of the parallelograms has been given. Calculate the length of the missing sides. (a) \_\_\_\_\_ (b) \_\_\_\_\_

(a)

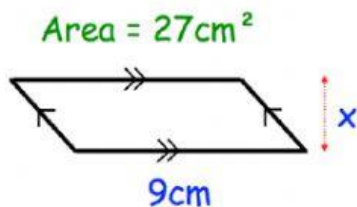

(b)

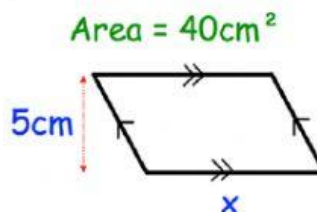

## Apply

**Question 2:** Find x

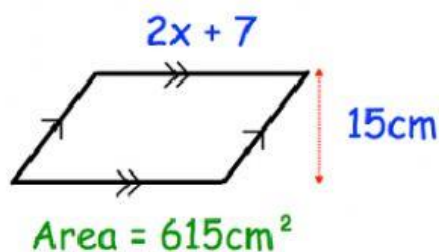

X = \_\_\_\_\_

Drag the Parallelogram answers from here

$8\text{cm}^2$	17cm	3cm	96
$6\text{cm}^2$	$16\text{cm}^2$	8cm	$20\text{cm}^2$

## Trapezoid

**Question 2:** Find the area of each trapezium.

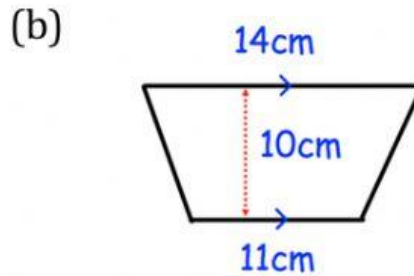
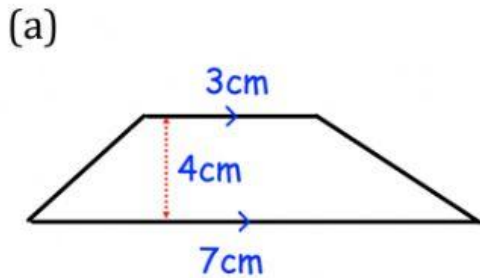

Drop (a) \_\_\_\_\_

(b) \_\_\_\_\_

**Question 3:** Find  $x$  for each trapezium.

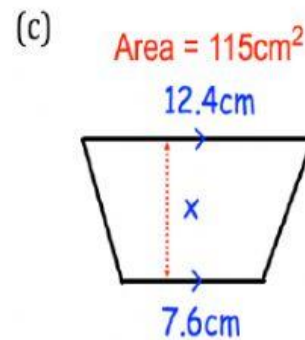
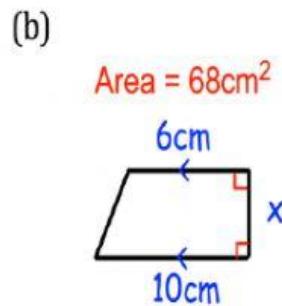
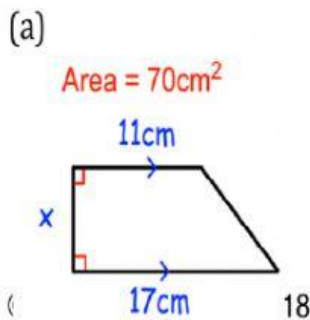

Drop: 3 (a) \_\_\_\_\_

(b) \_\_\_\_\_

(c) \_\_\_\_\_

**Question 4:** Find  $x$  for each trapezium.

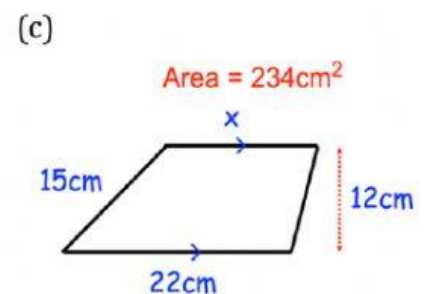
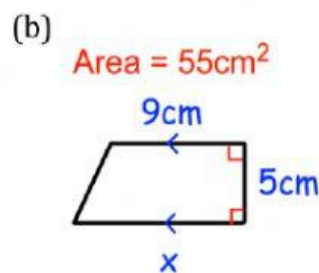
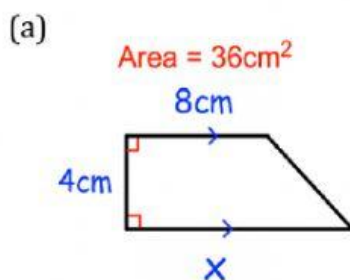

Drop: 4 (a) \_\_\_\_\_

(b) \_\_\_\_\_

(c) \_\_\_\_\_

10	17.7	20	5cm	17
125	11.5	102	13	8.5

**Apply: Drag the answers also from the table above**

**Question 2:** Mr. Taylor keeps chickens in the field shown. Each chicken needs  $3\text{m}^2$ . What is the maximum number of chickens she can keep in the field?

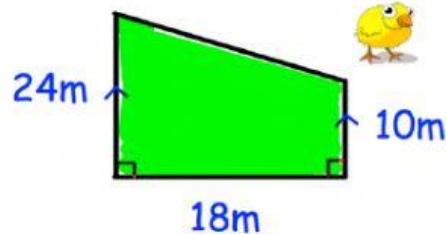

**Answer:** \_\_\_\_\_

**Question 3:** Shown is a rectangular garden. There is a Flowerbed in the shape of a trapezium. What percentage of the garden does the flowerbed cover? **Answer:** \_\_\_\_\_%

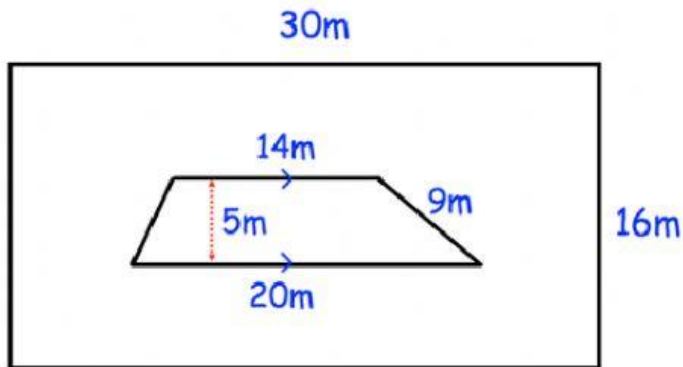

Upload your Image after you've checked your answers via [Class Point](#) or Line Id: [gpower11](#). By T.OJO